

Millett
SCOPE AND SIGHTING
DEVICE CATALOG

Millett
www.milletsights.com

LIT. Number: 9108451108

Millett Sights Salutes Our Military,
Police, Fire Fighters and
All First Responders



\$5.00

2009

BOP
9200 Cody, Overland Park, KS 66214
US: 1-800-221-9035 | Outside: 913-752-3400
Fax: 913-752-3550 / 800-548-0446

Produced in the USA by:
KTC | MEDIA GROUP
© Copyright 2009 Millett Industries Inc.

SIGHTING SOLUTIONS
TACTICAL | SPORTING | LAW ENFORCEMENT

2009 MILLETT TABLE OF CONTENTS

Table of Contents Millett 2009 New Products	02-03	Angle-Loc™ Aluminum Rings and Bases	15
Zoom-Dot™	04	See-Thru Saddle Mounts	16
Designated Marksman Scope Red-Dot	05	See-Thru Scope Mounts	17
Long-Range Tactical Scopes	06-07	Handgun Mounts	18
Buck Gold Series Scopes	08-09	Revolver Sights	19
Tactical Rifle Scopes	10	Series 100 Adjustable Sight System	20
Tactical Hardware	11	Rear Semi-Auto Sights	21
Turn-In Style Rings and Bases	12	Front Sights Rear Blades	22
Angle-Loc™ Windage Adjustable Rings	13	Installation Hardware Guarantee Disclaimers	23
Angle-Loc™ Windage Adjustable Rings and Bases AR-15 Flat Tops	14		



ULTRA RUGGED ZOOM DOT SIGHTING DEVICE

NEW LONG RANGE SCOPE W/ILLUMINATION CONTROL PG. 6-7

TACTICAL ADAPTER RINGS PG.11

NEW



ZOOM DOT™ NOW AVAILABLE PG. 04



TRS-SCOPE IMPROVEMENTS INCLUDING 1/4" MOA COME-UP MARKS PG. 10

NEW



NEW

20 MOA RAILS PG. 11



NEW

M16 HANDLE MOUNT PG. 11



NEW

SEE-THRU SADDLE MOUNT W/PICATINNY RAIL PG. 16



NEW

M1A - M14 MOUNTING SYSTEM PG. 11





ZOOM DOT™

The Millett Zoom Dot™ 30mm reflex sight is a non-magnifying 1-to-1 ratio red dot illuminated aiming system that can be used in all lighting situations with one or both eyes open. The dot size can be zoomed down to 1 MOA for a long-range accurate shot, or up to 10 MOA for super-fast target acquisition under close quarters battle, by simply turning the knob. Extensive testing on the S&W 500 mag and other high-impact weapons has proven that the ZOOM DOT is the most durable dot sight available. Its package size has been reduced, and a special mount is available for super-high-impact applications.

FEATURES

- Optical glass lenses –parallax free, multi-layer coating
- Unlimited eye relief – dot maintains point-of-aim
- Same batteries as the M68 weapon sight – 2L76 CR1/3N lithium battery
- Solid state field replaceable electronics
- Waterproof to 300'
- Comparable to current battery life for the M68 weapon sight – 1000 to 10,000 hours average life
- Approx. 5.5 inches long
- Weight: 8 oz
- Temp. range -50 to 160 F
- Withstands G forces beyond the levels encountered by small arm weapons (2000 Gs)
- 30mm tube

ZOOM DOT™

ZM00001	ZOOM DOT REFLEX SYSTEM
ZM00002	QUICK MOUNT
ZM00003	2-POINT MOUNTING ADAPTER RING
ZM00004	REPLACEMENT LENS COVERS



AUTOMATIC BRIGHTNESS ADJUSTMENT

The Millett Zoom Dot™ automatically adjusts dot brightness to match ambient light conditions, giving the warfighter a bright dot inside a dim building or outside on a snow covered field.



1-4X24 DESIGNATED MARKSMAN SCOPE

The Designated Marksman Scope fills the requirements of the law enforcement officer, rifle shooter, and the big game hunter who needs a quick-sighting system at ranges of 5 yards to 500 yards. The “Dot-in-a-Donut” reticle allows for fast, natural aiming. The shooter’s eye lines up the circle at close range, and the one MOA dot gives accuracy at the longer ranges. Range estimation is straight forward by use of the circle out to 500 yards. Compact design, 30mm tube, fully coated glass and bright illumination of the reticle are just a few of the many features of the DMS-1. Bright red illumination of the reticle adds to the quickness of the sighting system in day and low-light conditions. At 1 power it works well as a reflex sight and at longer ranges the 4X magnification gives increased accuracy.



BK81002

DONUT-DOT RETICLE

The Designated Marksman Scope Reticle offers quick sighting under the most demanding conditions of close combat or dangerous game. The “Dot-in-a-Donut” aligns naturally to give accurate shot placement at ranges of 3 meters to 400 meters. Range measurement by use of the known scale of the donut is a simple matter.

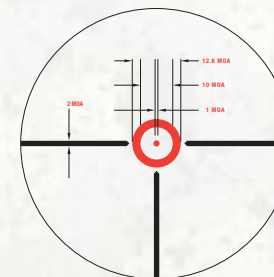

SP SERIES ELECTRONIC RED DOT™ SIGHTS

The Red Dot™ SP Series provides the ultimate in fast-sighting capabilities. The brightly illuminated red dot contrasts sharply against the background under bright and low-lighting conditions. Redot™ is waterproof and shockproof. All models have precision-click adjustments for windage and elevation. The handy dot intensity control switch has eleven settings for quick, fine-tune brightness adjustments. Sighting is crystal clear and parallax free. The 30mm Redot™ provides the competitive edge with an extra-wide field of view that’s wider than any other dot sight available in its class. The quality and performance is guaranteed. Only the best from Millett!

ELECTRONIC RED DOT™ SIGHTS

RD00004	SP-1 COMPACT	1 IN.	3 MIN DOT	MATTE
RD00904	SP-1 COMPACT	1 IN.	3 MIN DOT	SILVER
RD00005	SP-2 COMPACT	30MM	5 MIN DOT	MATTE
RD00905	SP-2 COMPACT	30MM	5 MIN DOT	SILVER
RD00006	MULTIDOT SP	30MM	3, 5, 8, 10 MIN DOT	MATTE
RD00906	MULTIDOT SP	30MM	3, 5, 8, 10 MIN DOT	SILVER
RD00010	LITHIUM BATTERIES	6 PAK		



MULTI-DOT SP IS COMPACT, YET HAS MAXIMUM VERSATILITY.

THE STANDARD IN HIGH-PERFORMANCE SIGHTING

LONG-RANGE SCOPE BY MILLETT

Millett expands its tactical line of rifle scopes with the Long-Range LRS-1 scope. The LRS-1 is the optic choice for the long-range hunter, tactical operator and target shooter who demands the best at an affordable price. The innovative design includes features found only in scopes several times more expensive than the LRS-1. Today, most scopes are built on a 1" or 30mm tube; however, the Millett LRS has a 35mm tube for added strength, brightness and clarity. As 35mm rings are hard to find and expensive, the LRS-1 comes with Millett tactical 35mm rings for ease of mounting. The 35mm tube offers added features that fit perfectly on heavy, hard-hitting, large caliber rifles used for extended ranges, such as the 50 BMG and 338 Lupua. Each Millett LRS-1 is computer tested under recoil to assure the highest quality. The LRS-1 scope is at home big game hunting in the west, target shooting at long ranges, or as a tactical scope for law enforcement use. The LRS-1 is a 6X 25X power zoom, with a 56mm front objective for the best light gathering. One feature which will be appreciated by the long-range shooter is the positive locking turrets with come-up counter for extended range shooting,

with 1/4 MOA clicks for windage and elevation adjustments, and over 140 MOA of adjustment. Few scopes have this extended range of adjustment. For most long-range shooting, there will be no need for special bases when using the LRS-1. Other features of the LRS-1, are fast side-focus for range parallax adjustment, and fully multi-coated lenses for sharp image at extended ranges. Millett's exclusive Mil-DotBar reticle is set at 1/2 Mil for added accuracy at the longer ranges. As a standard, Mil-Dot measures 36 inches at 1000 yards. The Millett Mil-DotBar reticle in the LRS-1 is 18 inches at 1000 yards - 1/2 Mil value to allow the shooter easy measurement and accuracy beyond 1000 yards. Each LRS-1 comes standard with lens shades, flip-open lens covers, along with a detailed operator manual and log book. A waterproof, hard anodized, subdued matte finish, makes for a truly rugged and durable scope. The Millett LRS-1 is solid and dependable, with features found in no other scope at this price range. It's a smart choice for the shooter needing the best in long-range scopes.

FEATURES INCLUDE:

- 6-25x
- 56mm objective
- 35mm tube diameter
- Fully multi-coated lenses
- Supplied with tactical rings
- 140 MOA elevation adjustment
- Locking windage and elevation target turrets
- Large settable windage and elevation knobs
- Positive 1/4 MOA or .1 MIL per click adjustments for windage and elevation
- Come-up scale on windage and elevation adjustments
- Quick side-focus range adjustment
- European-style eye focus
- Glass etched exclusive Mil-DotBar reticle
- Matte black finish one-piece T6 aluminum tube
- Lens shade supplied
- All Millett scopes are computer tested to assure quality

**NEW OPTIONAL ADJUSTMENTS
.1 MIL PER CLICK OR 1/4" MOA**



NEW

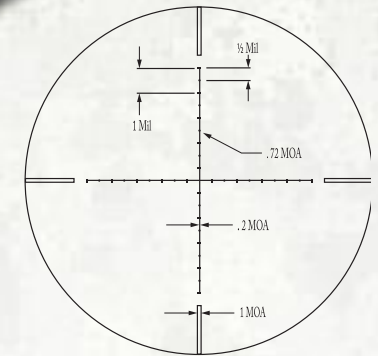

MIL-DOTBAR RETICLE CALIBRATED IN 1/2 MIL FOR LONG-RANGE ACCURACY



SCOPE SUPPLIED WITH LENS SHADE

SUPER BRIGHT,
SUPER STRONG
35MM TUBE

RAPID
SIDE-FOCUS
KNOB

140 MOA OF
ADJUSTMENT

LOCKING TURRETS
WITH COME-UP COUNTER

35MM RINGS SUPPLIED
WITH EACH SCOPE

EUROPEAN STYLE EYE FOCUS

NEW LRS ILLUMINATED

Long range shooters have ask for an illuminated reticle version of the LRS for times when the bright contrast of the glowing reticle helps to make the shot. The new model LRS illuminated will fill the needs of the most demanding shooter. All the features of the proven LRS with battery powered illumination. Settings from NV for the lowest light conditions to bright setting useable in sunny daylight. Like the TRS the new LRS illuminated reticle is green in color when the illumination is turned on to give the best contrast under all conditions.

LONG RANGE SCOPES

BK81004	6-25x	1/4 MOA CLICK	MULTI-COATED	MATTE
BK81005	6-25x	.1 MIL CLICK	MULTI-COATED	MATTE
BK81006	6-25x	1/4 MOA CLICK ILLUMINATED	MULTI-COATED	MATTE
BK81007	6-25x	.1 MIL CLICK ILLUMINATED	MULTI-COATED	MATTE



BUCK GOLD™ SERIES

MILLETT BUCK GOLD™ SERIES TARGET AND VARMINT SCOPES – AN EVEN BETTER BUCK.

Millett has taken scope design to the next step with the new model BUCK GOLD scopes. These are the culmination of all the improvements over the last years of Millett's 30mm target and varmint scopes, to give the shooter the most value for the money. A distinctive new look, with large, easy-to-use turret and side focus knobs add to the style of these scopes. Millett's proprietary Gimble Pivot increases accuracy and assures intertube alignment. Fully multi-coated optics and unique coil spring ensure sharpness and accuracy. Millett is proud to say "today's Millett scope is a vast improvement from just a few years ago." This year we have also added the Fine Crosshair and 1/8 MOA dot reticle for the target shooter and long-range varmint hunter.



BK30738

THE SIDE FOCUS SCOPE

This feature is a refinement in range focusing that allows the shooter to make fast and easy focus adjustments without moving head position and losing sight of the target. The range-focus knob is located on the left-hand side of the windage and elevation turret, where the range indicator scale can be easily seen. Simple accurate parallax adjustment.



SCOPE COVERS INCLUDED STANDARD ON ALL MILLETT BUCK GOLD VARMINT SCOPE, AND TACTICAL SCOPE

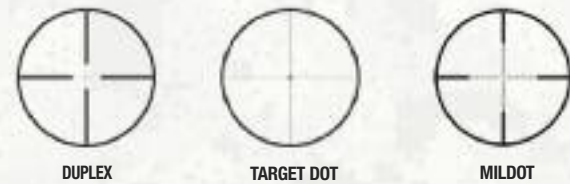

BUCK GOLD™ FEATURES

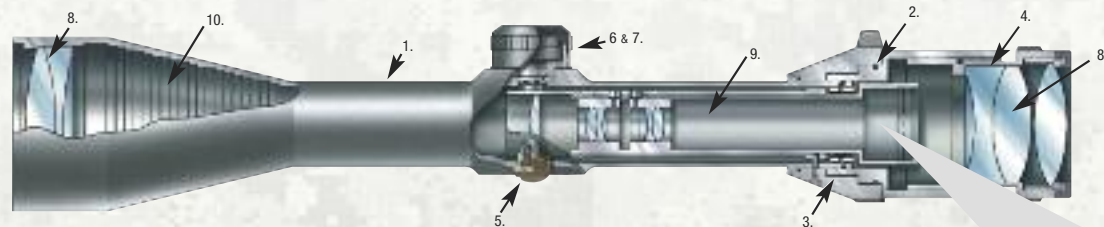

1. Heavy-duty, one-piece main tube, provides the foundation for precise lens alignment and other components.
2. Shock-proof scopes need to absorb the heaviest recoil and field handling conditions without failure. The soft mounting of lens assemblies and zoom gimble are protected inside the heavy-walled tube.
3. The reinforced variable power zoom ring serves to seal and support the eyepiece securely.
4. Our special sealing and purge methods for dry nitrogen fill include internal moisture removal paths in the eyepiece. The use of water resistant sealants, synthetic grease and secure O-ring seals protect against fogging over the life of the scope.
5. Buck Gold scopes have a unique coil spring system which applies uniform pressure to the zoom assembly throughout the windage & elevation adjustment range.
6. Resettable dials are provided in both windage and elevation adjustments to retain sight calibration and easy return to zero.
7. Finger-touch controls eliminate the need for coin slots. The fine clicks are graduated to produce 1/4 minute of angle corrections.
8. The multi-coated optics assure maximum light transmission for the sharpest image quality. Our lens design and assembly techniques will minimize off color fringe and color aberrations.
9. Parallax is controlled by the precise construction of zoom components that eliminate lost motion. This preserves the sharp focus at high, mid-range and low power. It accurately fits in sliding lens housings, zoom drive slots, and cam followers guarantee superior parallax elimination and reduce point-of-impact shifts throughout the zoom range.
10. Stray or flare light, that may reduce contrast and affect the image quality, is controlled by the use of our light baffles and anti-reflection coatings.

GIMBLE PIVOT

Unlike traditional ball joint pivots that eventually wear out, the Millett proprietary "Gimble Pivot", like a fine wine, only improves with age. All 30 mm Millett scopes now have "Gimble Pivots".

Patent Pending



NEW TACTILE KNOB DESIGN



FAST-FOCUS EYEPIECE



COIL SPRING SYSTEM



NEW FOR 2009 ON TARGET VARMINT SCOPES

LOCKING TURRETS: easy to use 1/4 turn locks the turret to prevent accidental movement of windage and elevation adjustments. Simple one screw cap retainers make for easy zero setting on elevation and windage. 1/8 MOA adjustments for accuracy on all target varmint scopes.

THE BUCK GOLD™ SERIES

NEW GENERATION TARGET VARMINT SCOPES

*BK30734	4-16 X 56 SIDE FOCUS	DUPLEX	MULTI COAT	MATTE
*BK30735	4-16 X 56 SIDE FOCUS	MILDOT	MULTI COAT	MATTE
*BK30736	4-16 X 56 SIDE FOCUS	FINEHAIR	MULTI COAT	MATTE
*BK30737	6-25 X 56 SIDE FOCUS	DUPLEX	MULTI COAT	MATTE
*BK30738	6-25 X 56 SIDE FOCUS	MILDOT	MULTI COAT	MATTE
*BK30739	6-25 X 56 SIDE FOCUS	FINEHAIR	MULTI COAT	MATTE

*Target scopes come with locking turrets in 2009

STATE-OF-THE-ART TEST FACILITY

We have developed computerized testing equipment that is capable of analyzing rapid firing scopes and red dots 60 times per second at up to 2000 G's. This equipment analyzes focus and point-of-aim changes under simulated field conditions to ensure that you get the best from Millett. As of 2007, all Millett scopes are 100% computer tested to assure the highest quality control.

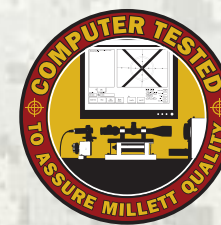

ALL MILLETT SCOPES 100% COMPUTER TESTED



TACTICAL RIFLE

Since the introduction of the TRS-1 in 2007, we have made several improvements from feedback and evaluation, and have developed an even better tactical scope. Now, each TRS-1 has the Millett Mil-DotBar reticle that makes it easy to range and figure MILs (see picture of reticle). We have changed the brightness of the green reticle to a lower level on the illuminated reticle, giving a better low-light use.

We have put a detent at 10X power for ease-of-use of the Mil-DotBar reticle, and we have removed the reflective markings to make the scope more stealth. In 2007, the TRS-1 was joined by the TRS-2 fixed 10X scope with all of the same features for those who prefer a set-power scope. The Millett TRS-series scopes are a great value for the shooter and professional who want the best at a good price.

TRS-1

The TRS-1 gives the shooter bright and sharp optics, controls that are easy to see and use, plus many added features. The TRS-1 is designed to do the job no matter the conditions or the range. If you are serious about your scope, Millett's new tactical scope is the smart choice.

SPECIFICATIONS:

- **Magnification** 4-16x power with large easy-to-use zoom ring
- **Lenses** 50mm objective lens (All lenses are multi-coated for sharpness and brightness)
- **Lens shade** Standard
- **Tube diameter** 30mm one-piece
- **Scope weight** 1.75 lbs
- **Side-focus range** 10 yards to infinity
- **Windage & Elevation** 1/4" and .1 mil adjustments available
- **Crosshair** Mil-Dot illuminated with green color
- **Controls** Large easy-to-use controls even with gloves (All controls facing to rear for ease of checking settings from the shooter's position)

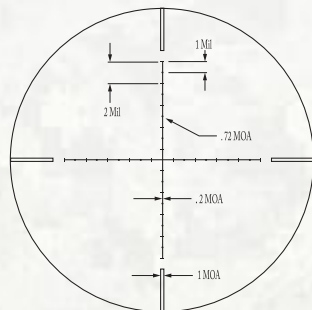

BK81001 4-16 X 50 TACTICAL MILLETT'S MIL-DOTBAR RETICLE™

Millett tactical scopes give the military, law enforcement and serious shooters the best in optics and features for the most demanding situations. Designed with input from those on the front lines, the Millett Tactical Scopes are rugged, easy-to-use, and priced right.

Millett's new Mil-DotBar reticle is an improvement of the standard Mil-Dot system. By having a thin line and a dot, it's easier to align for rangefinding and hold over. The same math for the standard Mil-Dot is used with the Millett Mil-DotBar system.

FEATURES INCLUDE:

- One-piece heavy aluminum tube for strength
- Bright, clear, multi-coated lens for sharpness under all light conditions
- Nitrogen filled for fog-proof lenses in cold and damp conditions
- 1/8 MOA click adjustment for accurate windage and elevation
- Side-focus ranging knob for accurate long-range shooting
- Large windage, elevation, zoom ring, and side-focus knobs with deep knurling for adjustments with gloves or when your hands are wet
- Adjustable, illuminated green Mil-Dot crosshairs for shooting in low-light conditions
- Illuminated control knob is at 45 degrees to allow unobstructed viewing of elevation setting
- Glass-etched reticle for strength and accuracy
- Quick eye-focus knob to allow easy crosshair focus
- Zoom-power ring larger than body of scope for ease of reading power setting
- 30mm body tube for the brightest image
- Lens shade standard



TRS-2 FIXED 10X SCOPE

This scope has all of the features of the TRS-1 Tactical 4X16X Zoom, but in a fixed power. 10 power is considered by many tactical shooters as the optimal power for their scope. This scope comes standard with the Millett Mil-DotBar reticle.



ZERO SET CAP WITH ONLY ONE SIMPLE SCREW AND 1/4" MOA OR .1 MIL WITH COME-UP MARKS

The TRS models will have the following improvements in 2009:

- Come-up counters on the turret, so you can determine the number of turns of the elevation and windage knobs have been moved. Easy to use markings make it easy to return to zero or come up to a setting. Each line on the turret is one full turn of the adjustment knob. The TRS can still be used as true tactical scope using the mil dot bar to hold over or the shooter can come up to the sight setting by turning the knobs.
- Lower brightness for illumination control: Many shooters have asked for lower settings on the TRS. In 2009 the settings for NV to level 5 are reduced in brightness 40% giving more useful range of illumination. The bright settings are still the same bright green that shooters have appreciated since the TRS hit the market.
- Windage and elevation adjustments change to 1/4 MOA and .1 Mil dot. You have a choice of a TRS in 1/4 inch clicks or .1 mil dot in 2009. At 100 yards it takes 4 clicks to make one inch of movement. With the TRS in MILs it takes 10 clicks to make 3.6 inches at 100 yards. Less turns and easier to figure for come ups with the new generation TRS. The TRS still has an ample 90 MOA of adjustment.
- One screw turret knobs: Instead of having to loosen 3 small screws on the windage and elevation turrets as the TRS as been in the past, the new model now has only one large screw on top of the knob for ease of setting the zero mark. The screw is held in place so you can't lose it when it's loosened.
- Zoom ring smaller in over all diameter. Some users of the TRS have complained of their bolt handle hitting the zoom ring on the TRS. We have reduced the size of the ring to help eliminate this problem. Still has the positive grip that allow the controls to be used with gloves.

The newest generation TRS is even better and more suited to the needs of today's tactical officer and shooter. The other features that have made the TRS a winner are still there, turret-loc, excellent glass, positive clicks, strong 30mm tube, all controls visible from the shooter's position, Check them out at your dealer.

TACTICAL RINGS

Millett Tactical Rings are a light-weight, strong solution for the most demanding uses. Six cap-clamping screws positively hold your scope, no matter the level of recoil and the base clamp holds the scope to the base. High, medium, and low heights come in a matte finish. Millett tactical rings are your answer to demanding mount needs.



TACTICAL SCOPE RING W/ACCESSORY RAIL

Millett's new Tactical Accessory Mount Scope Ring allows the mounting of lights, lasers, back-up sights and other items above the objective of 30mm scopes. Simple Picatinny rail mount allows ease-of-mounting with clamping-type Weaver rings. Available in low, medium, and high ring heights. Positive, sure mounting for your scope and easy-to-use accessory mount all-in-one.

GRABBER™

The Grabber™, in 1 inch and 30mm, is the answer for quick, easy, repeatable mounting of scopes and other tactical tools, such as lights and lasers on Weaver, Picatinny-type rails. Manufactured with heat-treated steel for strength, the Grabber returns to zero every time. A 5-to-1 mechanical advantage locks the Grabber to the rail without cams and weak components. For quick, positive mounting, go with the Grabber.



PATENT PENDING

TACTICAL RINGS			
DT00713	30 MM	LOW	MATTE
DT00714	30 MM	HI	MATTE
DT00715	30 MM	MED	MATTE
DT00716	1 IN	LOW	MATTE
DT00717	1 IN	MED	MATTE
DT00718	1 IN	HIGH	MATTE
GRABBER™ RINGS 1 IN			
GB00001	1 IN	MED	SMOOTH
GB00002	1 IN	MED	MATTE
GB00003	1 IN	MED	ENGRAVED
GRABBER™ RINGS 30 MM			
GB30001	30MM	MED	SMOOTH
GB30002	30MM	MED	MATTE
PICATINNY RAIL			
PC00001	REMINGTON 700 SHORT ACTION RIGHT HAND		MATTE
PC00002	SAVAGE ACCU-TRIGGER, SHORT ACTION RIGHT HAND		MATTE
PC00003	BLANK TACTICAL		MATTE
PC00005	REMINGTON 700 LONG ACTION RIGHT HAND		MATTE
PC00006	SAVAGE ACCU TRIGGER, LONG ACTION RIGHT HAND		MATTE
22 TIP OFF RISER RAILS			
R100001	TIP OFF RISER	.22 CAL	SEMI-AUTO MATTE
R100002	TIP OFF RISER	.22 CAL	BOLT ACTION MATTE
M4 RISER RAIL			
RI00003	M4 RISER .625 INCH HIGH		MATTE
20 MOA RAILS			
PC00009	REMINGTON	SA	RH 20 MOA
PC00010	REMINGTON	LA	RH 20 MOA
PC00011	SAVAGE ACCU TRIGGER	SA	RH 20 MOA
PC00012	SAVAGE ACCU TRIGGER	LA	RH 20 MOA
M1A – M14 MOUNTING SYSTEM			
PC00014	M14/M1A SCOPE MOUNT PICATINNY RAIL		
M16 HANDLE MOUNT			
PC00016	M16/AR15 HANDLE SCOPE MOUNT PICATINNY RAIL		

PICATINNY RAILS

Millett's Picatinny Rails are offered for the Remington 700 LA + SA right hand, Savage Accu-trigger LA + SA right hand, and also in the blank tactical. The easy, strong mounting system is similar to US military 1913 mounts. You can mount a wide range of optics using this rail, from red dots to large target scopes. The rails are heat treated T6 aluminum, black anodized with all required hardware for mounting. Millett's Picatinny Rails are priced right and give that custom look to any rifle.



22 RISER RAILS

Risers for rimfire rifles are available in two models – one for bolt action that is cut out for easy loading and the other for semi-automatic. Allows easy mounting of large objective scopes



M4 RISER RAILS

Millett's M4 riser allows the mounting of scopes and other optics on flat top AR, M4 and other rifles using normal height scope rings. Solid and secure, the M4 riser allows proper cheek position for these style firearms. Riser clamps onto any Picatinny/Weaver-type base.



20 MOA RAILS

For long range rifle shooting many scopes do not have adequate adjustment for elevation to zero at the extended yardages. By using a Picatinny rail that is higher in the rear area than the front, such as our 20 MOA rail you can align your scope and give greater elevation adjustment. Millett's 20 MOA rail is manufactured to the highest standards using T6 aluminum for Remington and Savage bolt action rifles.



M1A – M14 MOUNTING SYSTEM

Improved over the military and civilian bases of the past, the Millett M1A mount is solid T6 and fits all military and aftermarket receivers. Requires removal of the stripper clip guide at the rear receiver just in front of the rear sight. Improved thumb screw for easy tightening. Clamping screw on the forward part of the rail to assure zero. Positive hold and easy to remove and install. Strong enough for the largest scope, the M1A mount is ready for any mission.



M16 HANDLE MOUNT

Simple one nut installation on the carry handle of any standard M16 AR15 type rifle the Millett M16 mount is easy to use and gives the shooter a quick mount for scopes and sights like the Zoom Dot. The rails extended length allows a wider range of mounting options for scopes and reflex sights. Strong T6 aluminum and precision machined Picatinny rail to give the best accuracy, the Millett M16 rail mount is an excellent mounting solution. No tools required to install Millett M16 mount.



TURN-IN STYLE RINGS & BASES

When you select Millett scope mounts, you will own the highest quality rings and bases money can buy. They're custom crafted in heat-treated nickel-steel. All excess weight is removed with many unique design features found only on Millett rings and bases.



SMOOTH ENGRAVED SILVER MATTE

TURN-IN STANDARD RINGS

EXTENSION RINGS 1 IN.

SR00001	LOW	SMOOTH
SR00002	MED	SMOOTH
SR00003	HIGH	SMOOTH
SR00008	EX HI	SMOOTH
SR00701	LOW	MATTE
SR00702	MED	MATTE
SR00703	HIGH	MATTE
SR00708	EX HI	MATTE
SR00901	LOW	NICKEL
SR00902	MED	NICKEL
SR00903	HIGH	NICKEL
SR00908	EX HI	NICKEL
ER00001	LOW	ENGRAVED
ER00002	MED	ENGRAVED
ER00003	HIGH	ENGRAVED

TURN-IN STANDARD RINGS

EXTENSION RINGS 30MM

SR00004	LOW	SMOOTH
SR00005	MED	SMOOTH
SR00006	HIGH	SMOOTH
SR00704	LOW	MATTE
SR00705	MED	MATTE
SR00706	HIGH	MATTE
SR00904	LOW	NICKEL
SR00905	MED	NICKEL
SR00906	HIGH	NICKEL

ULTRA-LIGHT TWO-PIECE BASES

Our Two-Piece bases are easy to install and are rock-solid. They're also the lightest steel sets available. Designed for all popular models, these precision-fit parts provide maximum ejection port clearance and access with 30-50% less weight.



TURN-IN TWO-PIECE BASES

BROWNING

BB00005	A-BOLT	SMOOTH
BB00705	A-BOLT	MATTE
BB00905	A-BOLT	NICKEL
BB00004	BLR, BAR	SMOOTH

FN MAUSER SERIES, INTERARMS

FN00002	FN SERIES, INTERARMS MARK X	SMOOTH
FN00004	MAUSER 96	SMOOTH

KIMBER OF AMERICA

KM00001	KIMBER MODEL 82C & 84C	SMOOTH
---------	------------------------	--------

MARLIN

MB00007	336	SMOOTH
---------	-----	--------

REMINGTON, WHEATHERBY

SB70001	REM 700 SERIES, WHEATHERBY	SMOOTH
SB70701	REM 700 SERIES, WHEATHERBY	MATTE
SB70901	REM 700 SERIES, WHEATHERBY	NICKEL
RB00006	REM 7400, 7600, 4, 6, AMT	SMOOTH
RB00906	REM 7400, 7600, 4, 6, AMT	NICKEL
RB00007	REM 740, 742, 760	SMOOTH
RB00907	REM 740, 742, 760	NICKEL

SAVAGE

SB00009	110, 111, 112, 114, 116	SMOOTH
SB00709	110, 111, 112, 114, 116	MATTE
SB00909	110, 111, 112, 114, 116	NICKEL

WINCHESTER & MARLIN MR-7

WB70003	70 SERIES	SMOOTH
WB70703	70 SERIES	MATTE
WB70903	70 SERIES	NICKEL
WB00008	94, ANGLE-EJECT	SMOOTH

RINGS

Millett rings are the strongest and best quality available today. The unique, solid one-piece design eliminates the risk of separation under recoil due to poorly braised joints.

STANDARD EXTENSION RINGS

EXTENSION RINGS 1 IN.

EX00001	MED (STD R EXT F)	SMOOTH
EX00002	MED (EXT R STD F)	SMOOTH
EX00003	MED (EXT R EXT F)	SMOOTH
EX00004	HIGH (STD R EXT F)	SMOOTH
EX00005	HIGH (EXT R STD F)	SMOOTH
EX00006	HIGH (EXT R EXT F)	SMOOTH
EX00901	MED (STD R EXT F)	NICKEL
EX00902	MED (EXT R STD F)	NICKEL
EX00903	MED (EXT R EXT F)	NICKEL
EX00904	HIGH (STD R EXT F)	NICKEL
EX00905	HIGH (EXT R STD F)	NICKEL
EX00906	HIGH (EXT R EXT F)	NICKEL

STANDARD EXTENSION RINGS

EXTENSION RINGS 30MM

EX00007	MED (STD R EXT F)	SMOOTH
EX00008	MED (EXT R STD F)	SMOOTH
EX00009	MED (EXT R EXT F)	SMOOTH
EX00010	HIGH (STD R EXT F)	SMOOTH
EX00011	HIGH (EXT R STD F)	SMOOTH
EX00012	HIGH (EXT R EXT F)	SMOOTH
EX00907	MED (STD R EXT F)	NICKEL
EX00908	MED (EXT R STD F)	NICKEL
EX00909	MED (EXT R EXT F)	NICKEL
EX00910	HIGH (STD R EXT F)	NICKEL
EX00911	HIGH (EXT R STD F)	NICKEL
EX00912	HIGH (EXT R EXT F)	NICKEL



SCOPE MOUNT FEATURES & SPECIFICATIONS

RING	A-HEIGHT	B-HEIGHT	C-HEIGHT	D-HEIGHT	E-HEIGHT	F-HEIGHT
1 IN	.145	.265	.395	.500	.265	.395
30mm	.206	.350	.495		.350	.495

ANGLE-LOC™ WINDAGE ADJUSTABLE WEAVER-STYLE RINGS

The Angle-Loc™ windage-adjustable scope mount system is the most significant improvement to the traditional Weaver-Style mount in many years. All components are made of heat-treated nickel-steel for rock-solid durability. When compared to others, Millett scope mounts can't be beat.



SMOOTH ENGRAVED NICKEL MATTE

ANGLE-LOC™ WINDAGE ADJUSTABLE 1 IN. SCOPE RINGS

SMOOTH RINGS 1 IN.		
AL00010	LOW	
AL00011	MED	
AL00012	HIGH	
MATTE RINGS 1 IN.		
AL00710	LOW	
AL00711	MED	
AL00712	HIGH	
AL00722	EXTRA HIGH AR-15 FLAT TOP	

NICKEL RINGS 1 IN.		
AL00910	LOW	
AL00911	MED	
AL00912	HIGH	
ENGRAVED RINGS 1 IN.		
AL00007	LOW	
AL00008	MED	
AL00009	HIGH	

ANGLE-LOC™ WINDAGE ADJUSTABLE 30MM SCOPE RINGS		
SMOOTH RINGS 30MM		
AL00016	LOW	
AL00017	MED	
AL00018	HIGH	
MATTE RINGS 30MM		
AL00716	LOW	
AL00717	MED	
AL00718	HIGH	
NICKEL RINGS 30MM		
AL00916	LOW	
AL00917	MED	
AL00918	HIGH	

ANGLE-LOC™ WINDAGE ADJUSTABLE .22 CALIBER SCOPE RINGS		
SMOOTH 1 IN. MATTE 1 IN.		
TP00001	LOW	TP00701 LOW
TP00002	MED	TP00702 MED
TP00005	HIGH	TP00705 HIGH
NICKEL 1 IN. ENGRAVED 1 IN.		
TP00901	LOW	TP00012 LOW
TP00004	MED	TP00003 MED
TP00007	HIGH	TP00006 HIGH

.22 CAL SCOPE RINGS 30MM		
TP00008	MED	SMOOTH
TP00708	MED	MATTE
TP00908	MED	NICKEL
.22 CAL 11MM EURO GROOVED RECEIVER RINGS		
TP00713	MED	SMOOTH MATTE
TP00714	HIGH	1 IN. MATTE
TP00715	HIGH	30MM MATTE

ANGLE-LOC™ WINDAGE ADJUSTABLE ADJUSTABLE RUGER SCOPE RINGS

RUGER M77, SUPER REDHAWK 1 IN.		
RR77004	MED	SMOOTH
RR77904	MED	NICKEL
RR77005	HIGH	SMOOTH
RR77905	HIGH	NICKEL
RUGER M77, SUPER REDHAWK 30MM		
RR77006	MED	SMOOTH
RR77906	MED	NICKEL
RR77007	HIGH	SMOOTH
RR77907	HIGH	NICKEL

77/22, 1, 3, 96/44, RANCH, REDHAWK 1 IN.		
RM00010	MED	SMOOTH
RM00910	MED	NICKEL
RM00011	HIGH	SMOOTH
RM00911	HIGH	NICKEL
77/22, 1, 3, 96/44, RANCH, REDHAWK 30MM		
RM00013	MED	SMOOTH
RM00913	MED	NICKEL
RM00014	HIGH	SMOOTH
RM00914	HIGH	NICKEL

ANGLE-LOC™ WINDAGE ADJUSTABLE ADJUSTABLE RUGER 10/22		
RINGS FIT FACTORY SUPPLIED BASE		
RUGER 10/22, 96/22 1 IN.		
RM00026	MED	SMOOTH
RM00926	MED	NICKEL
RM00027	HIGH	SMOOTH
RM00927	HIGH	NICKEL
RUGER 10/22, 96/22, 30 MM		
RM00028	MED	SMOOTH
RM00928	MED	NICKEL

RINGS FIT WEAVER T0-9 BASE		
RUGER 10/22, 96/22 1 IN.		
RM00020	LOW	SMOOTH
RM00920	LOW	NICKEL
RM00021	MED	SMOOTH
RM00921	MED	NICKEL
RM00022	HIGH	SMOOTH
RM00922	HIGH	NICKEL

ANGLE-LOC™ WINDAGE ADJUSTABLE CZ/BRNO SCOPE RINGS		
1 IN. CZ-527 30MM		
BN00001	LOW	BN00006 LOW
BN00002	MED	BN00007 MED
BN00003	HIGH	BN00008 HIGH
1 IN. ZKM-611, 452 30MM		
BN00009	LOW	BN00012 LOW
BN00010	MED	BN00013 MED
BN00011	HIGH	BN00014 HIGH
1 IN. ZKK-600, 601, 602, CZ-550 30MM		
BN00015	LOW	BN00018 LOW
BN00016	MED	BN00019 MED
BN00017	HIGH	BN00020 HIGH
RUGER 10/22, 96/22, 30 MM		
RM00023	LOW	SMOOTH
RM00923	LOW	NICKEL
RM00024	MED	SMOOTH
RM00924	MED	NICKEL
RM00025	HIGH	SMOOTH
RM00925	HIGH	NICKEL

1 IN. SCOPE RINGS • 30 MM SCOPE RINGS
30 MM EXTENSION RINGS • .22 CALIBER SCOPE RINGS
TWO-PIECE BASES • SAKO SCOPE RINGS
TIKKA SCOPE RINGS • CZ/BRNO SCOPE RINGS
RUGER SCOPE RINGS • RUGER 10/22

ANGLE-LOC™ WINDAGE ADJUSTABLE SAKO SCOPE RINGS

SMOOTH 1 IN. NICKEL	
SA00010	LOW SA00910 LOW
SA00011	MED SA00911 MED
SA00012	HIGH SA00912 HIGH
SMOOTH 30 MM NICKEL	
SA00021	LOW SA00921 LOW
SA00022	MED SA00922 MED
BSA00023	HIGH SA00923 HIGH

EXTENSION RINGS 1 IN.	
EX20014	MED (EXT R STD F)
EX20015	MED (EXT F STD R)

ANGLE-LOC™ WINDAGE ADJUSTABLE TIKKA SCOPE RINGS

MATTE 1 IN. NICKEL	
TK00001	LOW TK00901 LOW
TK00002	MED TK00902 MED
TK00003	HIGH TK00903 HIGH
MATTE 30 MM NICKEL	
TK00006	LOW TK00906 LOW
TK00007	MED TK00907 MED
TK00008	HIGH TK00908 HIGH

ANGLE-LOC™ WINDAGE ADJUSTABLE CZ/BRNO SCOPE RINGS		
1 IN. CZ-527 30MM		
BN00001	LOW	BN00006 LOW
BN00002	MED	BN00007 MED
BN00003	HIGH	BN00008 HIGH
1 IN. ZKM-611, 452 30MM		
BN00009	LOW	BN00012 LOW
BN00010	MED	BN00013 MED
BN00011	HIGH	BN00014 HIGH
1 IN. ZKK-600, 601, 602, CZ-550 30MM		
BN00015	LOW	BN00018 LOW
BN00016	MED	BN00019 MED
BN00017	HIGH	BN00020 HIGH
RUGER 10/22, 96/22, 30 MM		
RM00023	LOW	SMOOTH
RM00923	LOW	NICKEL
RM00024	MED	SMOOTH
RM00924	MED	NICKEL
RM00025	HIGH	SMOOTH
RM00925	HIGH	NICKEL

CZ-452 "American Classic" 30MM		
BN00021	LOW	BN00024 LOW
BN00022	MED	BN00025 MED
BN00023	HIGH	BN00026 HIGH

USE OUR STD TP .22 CAL. RINGS

ALL STEEL ANGLE-LOC™ 2PC. BASES

Millett two-piece steel bases are 30 to 50 percent lighter than other brands. These two-piece bases are the perfect match for our very popular Angle-Loc™ rings. They are available in all three standard finishes. We have removed all of the excess weight without sacrificing any of the strength.



WORLD'S STRONGEST LIGHT-WEIGHT BASES.



Exclusive interlocking alignment guides.

All Millett ring tops are interchangeable for easy installation.

Less ring gap for cleaner lines and a stronger mount.

Recoil-proof magnum splines prevent scope slippage and dampen vibrations.

Millett Angle-Loc™ clamping system is windage adjustable and rock-solid.

All excess weight is removed, with no loss in strength.

Windage adjustable.

Bases are precision fit and won't move under heavy magnum recoil.



ANGLE-LOC™ WINDAGE ADJUSTABLE SCOPE EXTENSIONS

ALL STEEL ANGLE-LOC™ TWO-PIECE BASES

BROWNING A-BOLT WSM		REMINGTON 7400/7600	
ST00002	SMOOTH	ST00017	SMOOTH
ST00702	MATTE	SAUER 200	
ST00902	NICKEL	ST00013	SMOOTH
BROWNING A-BOLT WSSM		ST00713	MATTE
ST00016	SMOOTH	ST00913	NICKEL
INTERARMS MK X. FN.		SAVAGE 110	
MAUSER 98, PKER HALE		ST00010	SMOOTH
ST00004	SMOOTH	ST00710	MATTE
CVA OCTAGON		ST00910	NICKEL
ST00005	SMOOTH	SAVAGE 110 ACCU-TRIGGER	
ST00905	NICKEL	ST00015	SMOOTH
KNIGHT MK-85		ST00715	MATTE
ST00007	SMOOTH	ST00915	NICKEL
ST00907	NICKEL	SAVAGE 110 ACCU-TRIGGER COMBO ANGLE-LOC HIGH	
KNIGHT WOLVERINE		CP50703	MATTE
ST00008	SMOOTH	WINCHESTER 70, 70 WSM	
ST00908	NICKEL	ST00011	SMOOTH
REMINGTON 700, WEATHERBY MK V, VANGUARD		ST00711	MATTE
ST00009	SMOOTH	ST00911	NICKEL
ST00709	MATTE	WINCHESTER 70 WSSM	
ST00909	NICKEL	ST00018	SMOOTH
REMINGTON 798			
ST00019	SMOOTH		
ST00719	MATTE		

ANGLE-LOC™ WINDAGE ADJUSTABLE 1 IN. AND 30 MM EXTENSION RINGS

EXTENSION RINGS 1 IN.				EXTENSION RINGS 30 MM			
EX25001	MED	(1 EXT 1 STD)	SMOOTH	EX25007	MED	(1 EXT/1 STD)	SMOOTH
EX25003	MED	(2 EXT)	SMOOTH	EX25008	MED	(2 EXT)	SMOOTH
EX25004	HIGH	(1 EXT 1 STD)	SMOOTH	EX25009	HIGH	(1 EXT/1 STD)	SMOOTH
EX25006	HIGH	(2 EXT)	SMOOTH	EX25010	HIGH	(2 EXT)	SMOOTH
EX25901	MED	(1 EXT 1 STD)	NICKEL	EX25907	MED	(1 EXT/1 STD)	NICKEL
EX25903	MED	(2 EXT)	NICKEL	EX25908	MED	(2 EXT)	NICKEL
EX25904	HIGH	(1 EXT 1 STD)	NICKEL	EX25909	HIGH	(1 EXT/1 STD)	NICKEL
EX25906	HIGH	(2 EXT)	NICKEL	EX25910	HIGH	(2 EXT)	NICKEL

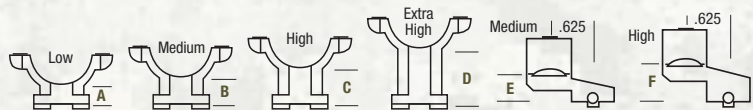

DETACHABLE MOUNT FEATURE & SPECIFICATIONS

RING	A-HEIGHT	B-HEIGHT	C-HEIGHT	D-HEIGHT	E-HEIGHT	F-HEIGHT
Angle-Loc 1 IN.	.275	.395	.525	1.017	.395	.525
Angle-Loc 30 MM	.319	.482	.626	-	.477	.622
.22 CAL 1 IN.	.290	.420	.594	-	-	-
.22 CAL 30 MM	-	.422	-	-	-	-
RUGER M77 1 IN.	-	R-.586 F-.473	R-.699 F-.586	-	-	-
RUGER M77 30 MM	-	R-.510 F-.397	R-.623 F-.510	-	-	-
SAKO 1 IN.	.412	.532	.662	-	.532	-
SAKO 30 MM	.347	.614	.759	-	-	-
TIKKA 1 IN.	.473	.586	.724	-	-	-
TIKKA 30 MM	.395	.508	.621	-	-	-
BRNO CZ, ZKM 1IN.	.473	.586	.724	-	-	-
BRNO CZ, ZKM 30 MM	.395	.508	.621	-	-	-
BRNO ZKK 1 IN.	.345	.460	.590	-	-	-
BRNO ZKK 30 MM	.404	.550	.698	-	-	-



AR-15 FLAT TOP

NUMBER	DESCRIPTION			
AL00722	AR-15 FLAT TOP RINGS	1.025 IN.	HIGH	MATTE

ANGLE-LOC™ DETACHABLE ALUMINUM RINGS & BASES

The new Angle-Loc™ Detachable scope mount system provides the same removable feature as the traditional Weaver-style mount. These rings have all of the excess weight removed to provide a slim new look. They are handsomely styled, very strong, and made of light-weight 100% aircraft quality aluminum. This new easily detachable ring can be removed and reattached with a coin. The Angle-Loc™ clamping system provides a rock-solid mounting with normal finger pressure on the clamp cross-bolt. It can also be attached with the use of the included Allen wrench. They are available in three finishes – bright, silver, and matte, to match your favorite scope finish. These light-weight aluminum rings are performance guaranteed to withstand the toughest field conditions. When compared to others, Millett scope mounts can't be beat!

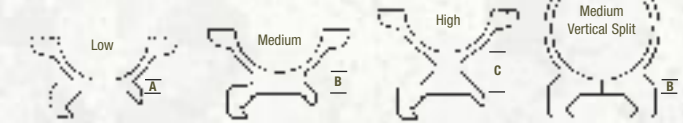

DETACHABLE MOUNT FEATURES & SPECS

ANGLE-LOC™	A-HEIGHT	B-HEIGHT	C-HEIGHT
Detachable 1 IN.	.115	.235	.470
Vertical Split 1 IN.	-	.220	-
Vertical Split 30 MM	-	.220	-

ALUMINUM ALLOY TWO-PIECE BASES

BROWNING			KNIGHT		
BB00715	A-BOLT	MATTE	KN00701	MK-85	MATTE
BB00915	A-BOLT	SILVER	KN00901	MK-85	SILVER
BB00716	BLR, BAR	MATTE	KN00702	WOLVERINE	MATTE
FN MAUSER SERIES, INTERARMS			KN00902	WOLVERINE	SILVER
FN00705	FN SERIES,		REMINGTON		
INTERARMS	MARK X	MATTE	SB70710	700 SERIES	MATTE
CVA, TRADITIONS			SB70910	700 SERIES	SILVER
CV00701	OCTAGON	MATTE	WINCHESTER & MARLIN MR-7		
CV00901	OCTAGON	SILVER	WB70706	70 SERIES	MATTE
CV00702	ROUND RECEIVER	MATTE	WB70906	70 SERIES	SILVER
CV00902	ROUND RECEIVER	SILVER	SAVAGE		
			SB00710	110	MATTE
			SB00711	ACCUTRIGGER	MATTE
			SB00910	110	SILVER

DETACHABLE ALUMINUM RINGS

RINGS 1 IN.			30MM		
DT00001	LOW	BRIGHT	DT00704	LOW	MATTE
DT00002	MED	BRIGHT	DT00705	MED	MATTE
DT00003	HIGH	BRIGHT	DT00706	HIGH	MATTE
DT00701	LOW	MATTE	22.CAL		
DT00702	MED	MATTE	DT00708	MED	MATTE
DT00703	HIGH	MATTE	DT00709	HIGH	MATTE
DT00901	LOW	SILVER	DT00908	MED	SILVER
DT00902	MED	SILVER	DT00909	HIGH	SILVER
DT00903	HIGH	SILVER			

ALUMINUM VERTICAL SPLIT RINGS

ALUMINUM VERTICAL SPLIT RINGS		
AL00019	MED 1 IN	BRIGHT
AL00719	MED 1 IN	MATTE
AL00919	MED 1 IN	SILVER
AL00020	MED 30MM	BRIGHT
AL00720	MED 30MM	MATTE
AL00920	MED 30MM	SILVER
VERTICAL SPLIT .22 CAL. ALUMINUM ALLOY RINGS		
TP00709	MED 1 IN	MATTE
TP00909	MED 1 IN	SILVER
TP00010	MED 30MM	BRIGHT
TP00710	MED 30MM	MATTE
TP00910	MED 30MM	SILVER



Now available in all three finishes

Made of 100% aircraft grade aluminum alloy

Easy to detach with a coin

Bases are precision-fit and won't move under heavy recoil

Less ring gap for cleaner lines and a stronger mount

Millett Angle-Loc™ clamping system is rock solid and detachable

Mounting screws are stronger than traditional Weaver-style bases

ALUMINUM ONE-PIECE BASES

MARLIN		
MB00708	336,30AS SERIES	MATTE
REMINGTON		
RB00707	7400, 7600, 4, 6	MATTE
RB00708	740, 742, 760, SAV170	MATTE
RUGER		
RU00701	10/22	MATTE
RE00901	10/22	SILVER



Combo Paks
See the price list for a complete listing. Special pricing available.

Angle-Loc™ Detachable 1 IN. SCOPE RINGS
VERTICAL SPLIT SCOPE RINGS
Vertical Split .22 CALIBER SCOPE RINGS
Aluminum Alloy

ONE-PIECE BASES
Aluminum Alloy
ONE-PIECE BASES
DETACHABLE COMBO PAKS

SEE-THRU SADDLE MOUNTS

Millett saddle mounts are custom styled for each model shotgun. The lines are smooth and trim with every bit of excess bulk removed. The operator side of the gun is completely cleared and free from obstruction. No more thumbustin' on protruding hardware. Millett saddle mounts are easy to install, and they provide a rock-solid foundation for your scope or red dot sight.

**NEW FOR 2009
ALL SEE THROUGH SADDLE
MOUNTS WILL COME WITH
PICATINNY 1913 RAILS**

**NEW**

**MOSSBERG 500, 835, 9200
12 GAUGE ONLY**



**WINCHESTER 1300, 1400, 1500,
12 GAUGE ONLY**



**REMINGTON 870, 1100, 1187
12 GAUGE AND 20 GAUGE**

SHOTGUN SADDLE MOUNTS

DESCRIPTION	PART No.
REMINGTON 870, 1100, 1187 12GA.	SE00020
REMINGTON 870, 1100, 1187 20GA.	SE00045
WINCHESTER 1300 12GA.	SE00021
WINCHESTER 1400, 1500 12GA.	SE00023
MOSSBERG 500, 835 12GA.	SE00022
MOSSBERG 9200 12GA.	SE00044

SEE-THRU SCOPE MOUNTS

MILLETT See-Thru Scope Mounts are machined from aircraft quality aluminum material to the tightest tolerances. Instead of simply being machined to fit a particular receiver's contour, all MILLETT See-Thru mounts feature our exclusive Sure-Fit™ Contact Rails. This unique three-point design accommodates any slight variation in the radius of the receiver, and provides the most rigid and accurate mounting system available.

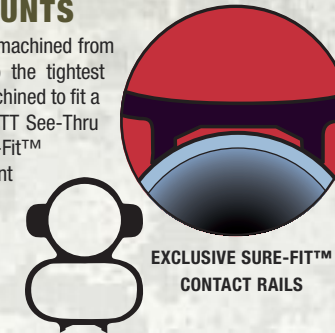

**EXCLUSIVE SURE-FIT™
CONTACT RAILS**

**SEE-THRU SCOPE MOUNTS**

MAKE & MODEL	SMOOTH	SILVER	MATTE
FITS WEAVER STYLE BASES	SE00030		SE00730
22 CAL RINGS	SE00014		SE00714
BROWNING BAR, BLR	SE00005		SE00705
BROWNING A-BOLT	SE00011	SE00911	SE00711
CVA, TRADITIONS OCTAGON	SE00032	SE00932	SE00732
CVA, TRADITIONS ROUND	SE00033	SE00933	SE00733
KNIGHT MK-85	SE00004	SE00904	SE00704
KNIGHT WOLVERINE, LEGEND	SE00026	SE00926	SE00726
MARLIN 336, 30AS	SE00006		SE00706
MAUSER 93, 94, 95, 96 SMALL RING			SE00734
MOSSBERG 500 SLUGSTER	SE00012		SE00712
MOSSBERG 835 SLUG GUN	SE00013		SE00713
REMINGTON 700, 721, 722, 725	SE00001	SE00901	SE00701
REMINGTON 740, 742, 760, SAV 170	SE00007		SE00707
REMINGTON 7400, 7600, 4, 6	SE00008		SE00708
RUGER 10/22	SE00009	SE00909	SE00709
SAVAGE 110, 111, 114, 116 NEW 12 SERIES	SE00002	SE00902	SE00702
T/C - HAWKEN**	SE00016		SE00716
T/C - RENEGADE **	SE00017		SE00717
T/C - HAWKEN TIMBER MOUNT***		SE00924	SE00724
T/C - RENEGADE TIMBER MOUNT***		SE00925	SE00725
T/C - FIREHAWK, THUNDERHAWK	SE00031	SE00931	SE00731
WINCHESTER 70, MARLIN MR7	SE00003	SE00903	SE00703
WINCHESTER 94 ANGLE EJECT	SE00010		SE00710
WINCHESTER 88, 100	SE00015		SE00715

** REQUIRES DRILLING AND TAPPING.
***SEE TIMBER MOUNT PHOTO. WILL ALSO FIT OTHER BLACK POWDER RIFLES.
WITH 15/16" AND 1" OCTAGON BARRELS. ROUND BARREL MODELS ALSO AVAILABLE.
SOME ITEMS DISCONTINUED - PLEASE CALL FOR AVAILABILITY.
CALL CUSTOMER SERVICE FOR INFORMATION.

**COMBINING FAST TARGET ACQUISITION WITH PRECISION
SIGHTING THESE MILLETT SEE THROUGH MOUNTS OFFER
THE MOST IN VERSATILITY FOR THE HUNTER.**



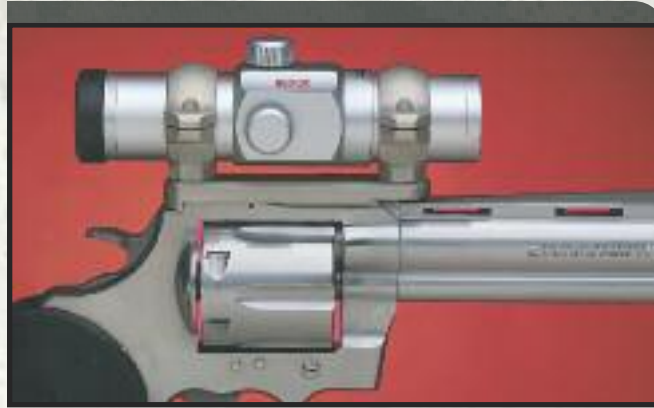

COLT ANACONDA & PYTHON MOUNT. DRILLING AND TAPPING REQUIRED.



RUGER BLACKHAWK, REDHAWK, SUPER BLACKHAWK, GP 100 MOUNT

HANDGUN MOUNTS

PART NO.	DESCRIPTION
COLT PYTHON, ANACONDA, PEACEKEEPER 8 BARREL	
RM00001	1 in. Rings Pre '95 Barrel Mount Smooth
RM00901	1 in. Rings Pre '95 Barrel Mount Nickel
CP00071***	1 in. Ring & Base Set Dbl Dovetail Low Smooth
CP00971***	1 in. Ring & Base Set Dbl Dovetail Low Nickel
CP00073***	30mm Ring & Base Set Dbl Dovetail Low Smooth
CP00973***	30mm Ring & Base Set Dbl Dovetail Low Nickel
CR00010***	Base Only Double Dovetail Smooth
CR00910***	Base Only Double Dovetail Nickel
DAN WESSON	
RM00004	1 in. 2 Ring Set .22 thru .357 Barrel Mount
RM00904	1 in. 2 Ring Set .22 thru .357 Brl Mt Nickel
RM00007	1 in. 3 Ring Set .41 & .44 Mag Barrel Mount
RM00907	1 in. 3 Ring Set .41 & .44 Mag Brl Mt Nickel
CP00075***	1 in. Ring & Base Set Dbl Dovetail Low Smooth
CP00975***	1 in. Ring & Base Set Dbl Dovetail Low Nickel
CP00077***	30mm Ring & Base Set Dbl Dovetail Low Smooth
CP00977***	30mm Ring & Base Set Dbl Dovetail Low Nickel
DW00010***	Base Only Double Dovetail Smooth
DW00910***	Base Only Double Dovetail Nickel
RUGER STANDARD AUTO MK I & MK II	
CP01017***	1 in. Angle-Loc Ring & Base Set Low Smooth
CP01917***	1 in. Angle-Loc Ring & Base Set Low Nickel
CP01019***	30mm. Angle-Loc Ring & Base Set Low Smooth
CP01919***	30mm Angle-Loc Ring & Base Set Low Nickel
RS22020***	ANGLE-LOC™ Base Only Smooth
RS22920***	ANGLE-LOC™ Base Only Nickel

HANDGUN MOUNTS CONTINUED

RUGER REDHAWK	
RM00009*	1 in. Rings Low Smooth
RM00909*	1 in. Rings Low Nickel
RM00012*	30mm Rings Low Smooth
RM00912*	30mm Rings Low Nickel
RUGER SUPER REDHAWK	
RR77004*	1 in. Rings Med Smooth
RR77904*	1 in. Rings Med Nickel
RR77006*	30mm Rings Med Smooth
RR77906*	30mm Rings Med Nickel
BLACKHAWK, REDHAWK, SUPER REDHAWK, GP-100, SECURITY SIX	
CP00079***	1 in. Ring & Base Set Dbl Dovetail Low Smooth
CP00979***	1 in. Ring & Base Set Dbl Dovetail Low Nickel
CP00081***	30mm Ring & Base Set Dbl Dovetail Low Smooth
CP00981***	30mm Ring & Base Set Dbl Dovetail Low Nickel
RR00010***	Base Only Double Dovetail Smooth
RR00910***	Base Only Double Dovetail Nickel
CP01013***	1 in. Angle-Loc Ring & Base Set Low Smooth
CP01913***	1 in. Angle-Loc Ring & Base Set Low Nickel
CP01015***	30mm. Angle-Loc Ring & Base Set Low Smooth
CP01915***	30mm Angle-Loc Ring & Base Set Low Nickel
RR00011***	ANGLE-LOC™ Base Only Smooth
RR00911***	ANGLE-LOC™ Base Only Nickel
SMITH & WESSON K, L & N ALL MODELS**	
PRE 1994 MODELS REQUIRE DRILLING AND TAPPING	
CP00057**	1 in. Dbl Dovetail Ring & Base Set Low Smooth
CP00957**	1 in. Dbl Dovetail Ring & Base Set Low Nickel
CP00063**	30mm. Dbl Dovetail Ring & Base Set Low Smooth
CP00963**	30mm Dbl Dovetail Ring & Base Set Low Nickel
RM00030**	Dbl Dovetail Base Only Smooth
RM00930**	Dbl Dovetail Base Only Nickel
CP01009**	1 in. Angle-Loc Ring & Base Set Low Smooth
CP01909**	1 in. Angle-Loc Ring & Base Set Low Nickel
CP01011**	30mm. Angle-Loc Ring & Base Set Low Smooth
CP01911**	30mm Angle-Loc Ring & Base Set Low Nickel
RM00031**	ANGLE-LOC™ Base Only Smooth
RM00931**	ANGLE-LOC™ Base Only Nickel
SW41001**	42.00 16.59 S&W 41 Auto Base Only Dbl Dovetail Smooth
TAURUS .44 MAG., 607*** Older Models with 0 Serial Numbers	
TA00010***	Base Only Double Dovetail Smooth
TA00910***	Base Only Double Dovetail Nickel
TAURUS .44, 608*** Newer Models with P Serial Numbers	
CR00010***	Base Only Double Dovetail Smooth
CR00910***	Base Only Double Dovetail Nickel
THOMPSON / CENTER CONTENDER, ENCORE	
CP00042	1 in. Dbl Dovetail Ring & Base Set Low Smooth
CP00942	1 in.. Dbl Dovetail Ring & Base Set Low Nickel
CP20042	1 in. Dbl Dovetail Ring & Base Set Med Smooth
CP20942	1 in. Dbl Dovetail Ring & Base Set Med Nickel
CP00065	30mm Dbl Dovetail Ring & Base Set Low Smooth
CP00965	30mm Dbl Dovetail Ring & Base Set Low Nickel
CP00066	30mm Dbl Dovetail Ring & Base Set Med Smooth
CP00966	30mm Dbl Dovetail Ring & Base Set Med Nickel
TC00001	Dbl Dovetail Base Only Smooth
TC00002	Dbl Dovetail Base Only Nickel
CP00053	1 in. Angel-Loc™ Ring & Base Set Low Smooth
CP00953	1 in. Angel-Loc™ Ring & Base Set Low Nickel
TC00003	Angle-Loc™ Base Only Smooth
TC00004	Angle-Loc™ Base Only Nickel
TC00006	T/C ENCORE Base Angle-Loc Only Smooth
TC00906	T/C ENCORE Base Angle-Loc Only Nickel
TC00007	T/C ENCORE 1 PC Base Turn-In Smooth
TC00008	T/C ENCORE 1 PC Base Angle-Loc Smooth
REMINGTON XP-100	
CP00039	1 in. Turn-In Ring & Base Set Med Smooth
CP00050	1 in. Angle Loc™ Ring & Base Set Low Smooth

* Rings for Factory Machined Revolvers
 ** Older Models Require Drilling and Tapping
 *** All Models Require Drilling and Tapping

REAR SIGHTS

Whether you're a handgun hunter or a target shooter, it seems as if most six-gunners find one or two favorite revolvers that eventually get a loving action-job, a change of grips, and an upgrade in sighting equipment. A clear crisp sight picture is a must.

FINE TUNE YOUR FAVORITE WHEELGUN WITH MILLETT REVOLVER SIGHTS.



MODEL	WHITE OUTLINE	TARGET		
COLT 312 HEIGHT FITS ADJUSTABLE SIGHT MODELS	CR00001 CR00003 (Silhouette)	CR00002		
DAN WESSON 312 HEIGHT FITS ALL MODELS .360" HEIGHT	DW00001 DW00004	DW00002		
* .41/.44 MAG BLUE STEEL C00021275/B023200 OR .41/44 MAG STAINLESS SC002354/S0008125 & UP ORDER DW00001 OR DW00002. FOR .41/.44 SERIAL NUMBERS LOWER THAN ABOVE, ORDER DW00003 OR DW00004				
RUGER 312 HEIGHT FITS ADJUSTABLE SIGHT MODELS	RR00001 RR00003 (Silhouette)	RR00002		
SMITH & WESSON K/L FRAME				
HT	BRL LENGTH	MODEL		
.312	2-21/2"	ALL	SW00011 New Rounded Tang	SW00012 New Rounded Tang
	4"	15, 18, 48, 53, 67, 617		
	6"	14, 53		
	8 3/8"	14, 53		
.360	2 1/2"	19, 66, 686	SW00013 New Rounded Tang	SW00014 New Rounded Tang
	4"	19, 66, 17, 586		
	6"	16, 17, 19, 48, 66, 67, 586, 686		
.410	ALL ADJUSTABLE FRONT SIGHT MODELS		SW00015 New Rounded Tang	SW00016 New Rounded Tang
SMITH & WESSON N FRAME				
.312	4"	25-5, 27.5", 28, 625-5"	SW00011 New Rounded Tang	SW00012 New Rounded Tang
	6"-6 1/2"	25-5, 28		
	8 1/2"	25-5		
.360	4"	25-5, 27.5"	SW00013 New Rounded Tang	SW00014 New Rounded Tang
	6"-6 1/2"	25-3, 24, 624, 27, 29, 629, 57, 625-2"		
	8 3/8"	25-2, 24, 624, 27, 29, 629, 57, 625-2"		
.410	1 5/8"	29 & ADJUSTABLE FRONT SIGHT MODELS	SW00015 New Rounded Tang	SW00016 New Rounded Tang
TAURUS				
PRIOR TO 1988 USE S&W "T" NUT WITH INSTALLATION		SW00013*	SW00014*	
*SIGHTS FOR PRE '74 & S&W K/N FRAME MODELS MUST BE DRILLED AND COUNTERSUNK BY GUNSMITH.				

FRONT SIGHTS



MODEL	WHITE BAR	ORANGE BAR
COLT PYTHON, ANACONDA DIAMONDBACK/KING COBRA/PEACEKEEPER, TROOPER	FB00007 FB00015	FB00008 FB00016
DAN WESSON HIGH FRONT FITS 15, .41/.44 LOW FRONT FITS .22 ONLY	FB00009 FB00011	FB00010 FB00012
RUGER - DOUBLE ACTION MODELS ONLY GP-100/ SUPER RED HAWK POLICE/SPEED 6 SECURITY 6 (OLD STYLE) SECURITY 6 (NEW STYLE) REDHAWK	FB00017 FB00001 FB00003 FB00013 FB00005	FB00018 FB00002 FB00004 FB00014 FB00006



THE BLAZE ORANGE FRONT SIGHT IS EASY TO SEE.



HIGH VISIBILITY BLAZE ORANGE FRONT SIGHT IS EASY TO CHANGE, NO GUNSMITHING REQUIRED ON GP-100, REDHAWK, & SUPER REDHAWK.



ADJUSTABLE REAR SIGHTS FOR ROUNDED TANG MODELS ARE AVAILABLE NOW. (SEE SELECTION CHART)





SERIES 100 ADJUSTABLE SIGHTS SYSTEMS

We first made a name for ourselves by producing superb handgun sights that set a new standard in the industry. With the introduction of several unique design features, handgunners everywhere changed from factory sights to Millett's series 100 adjustable sight system. These sights feature a positive light-deflection serration and slant to eliminate glare. The knife-edge rear sight notch allows for extra-crisp target definition. When precision adjustments for windage and elevation are made, you'll hear a positive, audible "click", indicating that the hardened screws and detents are locked into their settings. It's quality you can feel — and see in your marksmanship.

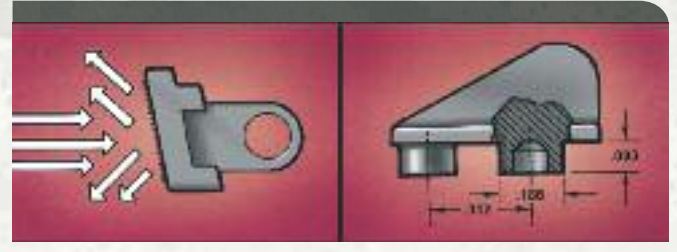

POSITIVE LIGHT DEFLECTION SYSTEM ELIMINATES ALL POSSIBLE GLARE **THE ROCK-SOLID DUAL-CRIMP™ FRONT SIGHT IS THE ULTIMATE SIGHT SOLUTION**

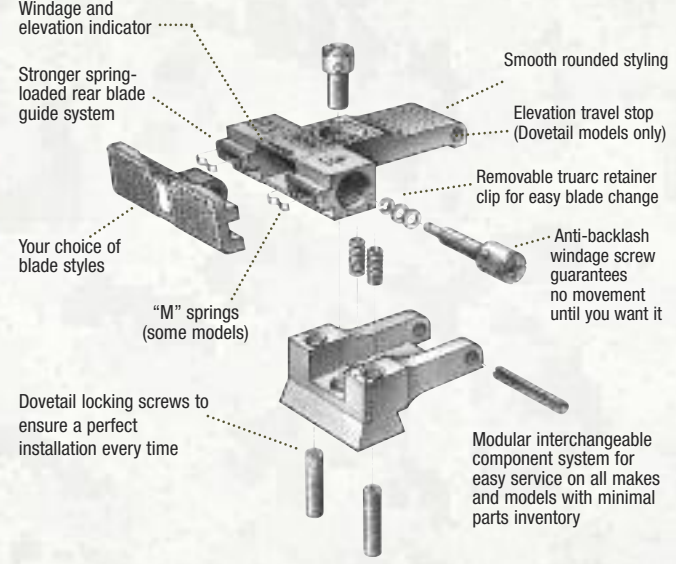

REAR SIGHTS

MODEL	WHITE OUTLINE	TARGET	3-DOT	MARKS-MAN	COMBO PAK
COLT 1911 GOV'T ADJUSTABLE .312 HEIGHT	CA00009 USE .312 FRONT	CA00010 USE .312 FRONT	CA00008 USE .312 FRONT	CA00018 USE .410 DC FRONT	YES
COLT CCLP ADJUSTABLE .360 HEIGHT Requires machining	CC00009 USE .225 FRONT	CC00010 USE .225 FRONT	CC00008 USE .225 FRONT	CC00015 USE .275 DC FRONT	YES
COLT GOLD CUP/ACE ADJUSTABLE .360 HEIGHT	GC00009 USE .200 FRONT	GC00010 USE .200 FRONT	GC00008 USE .200 FRONT	GC00018 USE .275 DC FRONT	YES
COLT MARK I FIXED	MK10005 USE .185 FRONT		MK10009 USE .185 FRONT		YES
COLT MARK II FIXED	MK20009 USE .200 FRONT	MK20010 USE .200 FRONT	MK20008 USE .200 FRONT		YES
AMT HARDBALLER ADJUSTABLE .312 HEIGHT	AM00001 .185DC	AM00002 .185DC			NO

MODEL	WHITE OUTLINE	TARGET	3-DOT	COMBO PAK
GLOCK 17, 17L, 19, 21, 22, 23 .312 HEIGHT	GL00001 USE .340 DC OR GLOCK FRONT	GL00002 USE .340 DC OR GLOCK FRONT	GL00008 USE .340 DC OR GLOCK FRONT	YES
SIG/SAUER P220 P224, P225, P226, P228 .312HEIGHT P220 OLD MODEL	SP22003 DOVETAIL FRONT DC FRONT	SP22004 DOVETAIL FRONT DC FRONT	SP22005 DOVETAIL FRONT DC FRONT	YES NO
RUGER P85, 89, 90, 94 .360 HEIGHT	RP85003 PIN-ON	RP85004 PIN-ON	RP85008 PIN-ON	YES
RUGER MARK I & II ALL MODELS .360 HEIGHT	RS22005	RS22014 TARGET RS22006 SILHOUETTE	RS22003	YES
BERETTA ACCURIZER™* FITS 84, 85, 92S, 92SB	BE00005 USE .325 BE FRONT	BE00006 USE .325 BE FRONT	BE00003 USE .325 BE FRONT	YES
BROWNING HI-POWER FITS FACTORY ADJUSTABLE SLIDE DOVETAIL FRONT ALL MODELS	BA00009 USE .340 FRONT USE .340 DT FRONT	BA00010 USE .340 FRONT USE .340 DT FRONT	BA00008 USE .340 DC FRONT	YES
BROWNING HI-POWER FITS OLD SMALL DOVETAIL FIXED SLIDE	BF00009 USE .340 DC OR SO FRONT	BF00010 USE .340 DC OR SO FRONT	BF00008 USE .340 DC OR SO FRONT	YES
BRUNO CZ-75/TZ-75/TA-90	CZ00001 USE .340 DC OR SO FRONT	CZ00002 USE .340 DC OR SO FRONT	CZ00003 USE .340 DC OR SO FRONT	NO
SMITH & WESSON 39/59	SW39595 USE .340 DC FRONT	SW39596 USE .340 DC FRONT		NO
SMITH & WESSON FITS FACTORY ADJUSTABLE SLIDE 2nd GENERATION	SW40505 USE .312 DC FRONT	SW40506 USE .312 DC FRONT	SW40504 USE .312 DC FRONT	NO
3rd GENERATION	USE .260 S & W DT FRONT	USE .260 S & W DT FRONT	USE .260 S & W DT FRONT	NO
SMITH & WESSON FACTORY FIX SLIDE 2nd GENERATION	SW46905 USE .312 DC FRONT	SW46906 USE .312 DC FRONT	SW46904 USE .312 DC FRONT	YES
3rd GENERATION	USE .385 DT FRONT	USE .385 DT FRONT	USE .385 DT FRONT	YES
TAURUS PT92	BA00009 USE BERETTA FRONT	BA00010 USE BERETTA FRONT	BA00008 USE BERETTA FRONT	NO



COLT - 1911 GOV'T



GLOCK



BROWNING HI-POWER



SIG/SAUER



SMITH & WESSON
2ND & 3RD GENERATION



RUGER



BERETTA "ACCURIZER"

THESE SIGHTS FIT ALL COLT 1911 STYLE MODELS MADE THROUGH 1998. THEY DO NOT FIT THE NEW DOVETAIL FRONT SIGHT MODELS.

FINE TUNE YOUR BERETTA AND REDUCE YOUR GROUP SIZE BY 30%.



FRONT SIGHTS

MILLETT front sights are easy to install using our special Dual-Crimp™/stake-on combination tool system. These sights come in a choice of White Bar, Blaze Orange Bar, Serrated Ramp, Plain Post and White Dot. Most of these styles are available in Dual-Crimp™, stake-on, or Dovetail-type installations.

	DUAL-CRIMP™	ORANGE BAR	WHITE BAR	3-DOT	SERRATED RAMP	PLAIN POST
.185 HEIGHT	DC18502	DC18501	DC18501	DC18500	DC18503	
.200 HEIGHT	DC20006	DC20005	DC20005	DC20004	DC20007	
.212 HEIGHT	DC21210	DC21209	DC21209	DC22512	DC21211	
.225 HEIGHT	DC22514	DC22513	DC22513	DC22512	DC22515	DC22516
.275 HEIGHT	DC27524	DC27523	DC27523	DC27529	DC27529	
.312 HEIGHT	DC31218	DC31217	DC31217	DC31216	DC31219	DC31220
.340 HEIGHT	DC34022	DC34021	DC34021	DC34020	DC34023	
.410 HEIGHT	DC41031	DC41030	DC41030	DC41032	DC41032	
STAKE-ON	ORANGE BAR	WHITE BAR	3-DOT	SERRATED RAMP	PLAIN POST	
.185 HEIGHT	S018502	S018501	S018500	S018503		
.200 HEIGHT	S020006	S020005		S020007		
.225 HEIGHT	S022514	S022513		S022515	S022516	
.312 HEIGHT	S031218	S031217		S031219	S031220	
.340 HEIGHT	S034022	S034021				
WIDE STAKE (FOR COLTS MADE AFTER 6/88) .125 WIDE TENON						
.185 HEIGHT	WS18502	WS18501	WS18504	WS18503		
.200 HEIGHT	WS20006	WS20005	WS20008	WS20007		
.225 HEIGHT	WS22502	WS22501	WS22504	WS22503		
.312 HEIGHT	WS31218	WS31217	WS31220	WS31219		

	ORANGE BAR	WHITE BAR	SERRATED RAMP	WHITE DOT	COMBO PAKS
GLOCK .340 STAKE-ON DUAL CRIMP™	GL00004 DC34022	GL00003 DC34021	GL00005 DC34023	GL00006 DC34020	YES
SIG/SAUER .360 DOVETAIL DUAL-CRIMP	SP22566 DC36026	SP22565 DC36025	SP22568 DC36027	SP22567 DC36024	YES
RUGER PIN-ON	RP85006	RP85005	RP85007	RP85009	YES
RUGER Mk I, II FIXED SIGHT MODELS	RS22008	RS22007	RS22009	RS22015	YES
TARGET ADJ MODELS	RS22011	RS22010			NO
BULL BARREL MODELS	RS22013	RS22012			NO
BERETTA / TAURUS	BE00008	BE00007	BE00010	BE00009	YES
DOVETAIL .340 BROWNING	FB00020	FB00019	FB00022	FB00021	YES
.260 S & W	SW40508	SW40507	SW40513	SW40509	YES
.385 S & W	SW46908	SW46907	SW46913	SW46909	YES

REAR BLADES

The series 100 adjustable rear sight system has several rear blade styles to choose from. Our white outline and blaze orange front combination is the most popular. All blades are interchangeable.

BLADE STYLE	ORDER NO.	BLADE HEIGHT DXW	NOTCH DIMENSIONS
WHITE OUTLINE	BL31201 BL36003 BL36008 BL41005	.312 .360 .360 .410	.065 X .125 .065 X .125 .085 X .080 .065 X .125
3-DOT	BL31200 BL36000	.312 .360	.065 X .125 .090 X .125
TARGET	BL31202 BL36004 BL41009	.312 .360 .410	.065 X .125 .090 X .125 .100 X .125
SILHOUETTE	BL36007 BL31206 BL36009	.360 .312 .360	.090 X .090 .065 X .090 .085 X .080
OPEN "V"	BL36011	.360	OPEN "V"
PEEP	BL00011 BL00010	.360 .360	.080 DIA. .050 DIA.

FLUSH-MOUNT SLING SWIVELS

MILLETT flush-mount sling swivels are smooth and snag free. They snap into place or remove with a simple push and a 90° twist. Adds a real custom look to your rifle. They are easy to install in wood or synthetic rifle stocks. Now available with threaded screw-in type bases.



FLUSH MOUNT SLING SWIVELS

ORDER NUMBER	DESCRIPTION
SS00002	LOOPS ONLY (1 PAIR)
SS00003	INSTALLATION DRILL
SS00004	HARRIS BIPOD ADAPTER
SS00006	COMBO BASES & LOOPS (SCREW-IN STYLE)
SS00007	BASES ONLY (SCREW-IN STYLE)

BENCHMASTER™ SHOOTING REST

RIFLE REST — The rear support is ramped so you can always find that perfect sweet spot that can elude you with other types of rests.

PISTOL REST — The convenient notch on the top of the pistol rest cradles the barrel or frame for a secure shooting platform. The rear portion of the rest is a sliding pad that reverses to fit gun-butt or hand, so that you get the perfect elevation and support.

WINDOW REST — Trying to brace a spotting scope, camera or binoculars on a car window can be a real pain. Not to mention a hazard to the health of your costly equipment and automobile. The window rest is an easy and affordable solution.

- Tough, "no mark" surface
- Soft, friendly feel
- Easy storage, back portion fits neatly inside the front
- No more heavy sand bags



BENCHMASTER™ SHOOTING REST

BR00001	RIFLE REST
BR00005	WINDOW REST
BR00009	PISTOL REST



INSTALLATION TOOLS

Now it's easy to install both Dual-Crimp™ and Stake-On front sights with the same tool! The new improved applicator tool is now interchangeable. The lower jaws can be conveniently exchanged to accommodate either Dual-Crimp™ or Stake-On front sight installations. You don't have to be a gunsmith to install Millett Sights quickly and easily.



DUAL-CRIMP/STAKE-ON COMBO TOOLS

DC00002	COMPLETE TOOL SET
DC00003	APPLICATION TOOL
DC00015	DUAL-CRIMP REPLACEMENT JAW
DC00016	STAKE-ON REPLACEMENT JAW
DC00004	REVERSE COUNTERSINK SOLID CARBIDE
DC00005	3/16 DRILL SOLID CARBIDE
DC00006	DRILL JIG ONLY
BS00009	BORESIGHTER WITH .45 & 9mm RODS
BS00013	.22 CAL ROD ONLY
BS00014	.41 CAL ROD ONLY
BS00015	.44 CAL ROD ONLY
BS00016	10mm, 40S&W CAL ROD ONLY
GK00010	GUNSMITH SERVICE KIT SERIES 100 SYSTEM
SA00008	SIGHT ADJUSTING TOOL SERIES 100 SYSTEM

GUARANTEE | DISCLAIMERS

We guarantee that every MILLETT product will be of unsurpassed quality and craftsmanship. If for any reason you are not completely satisfied, or experience a problem with any of our products, call us at 1-800-MILLETT. Prices and products subject to change without notice.

WE'RE HERE, AND READY TO HELP.

WARRANTY SERVICE REQUIRES SALES RECEIPTS.